

AUSTRALIAN STAINLESS

SPECIALISING IN STAINLESS STEEL AND ITS APPLICATIONS

#41
SPRING
2007

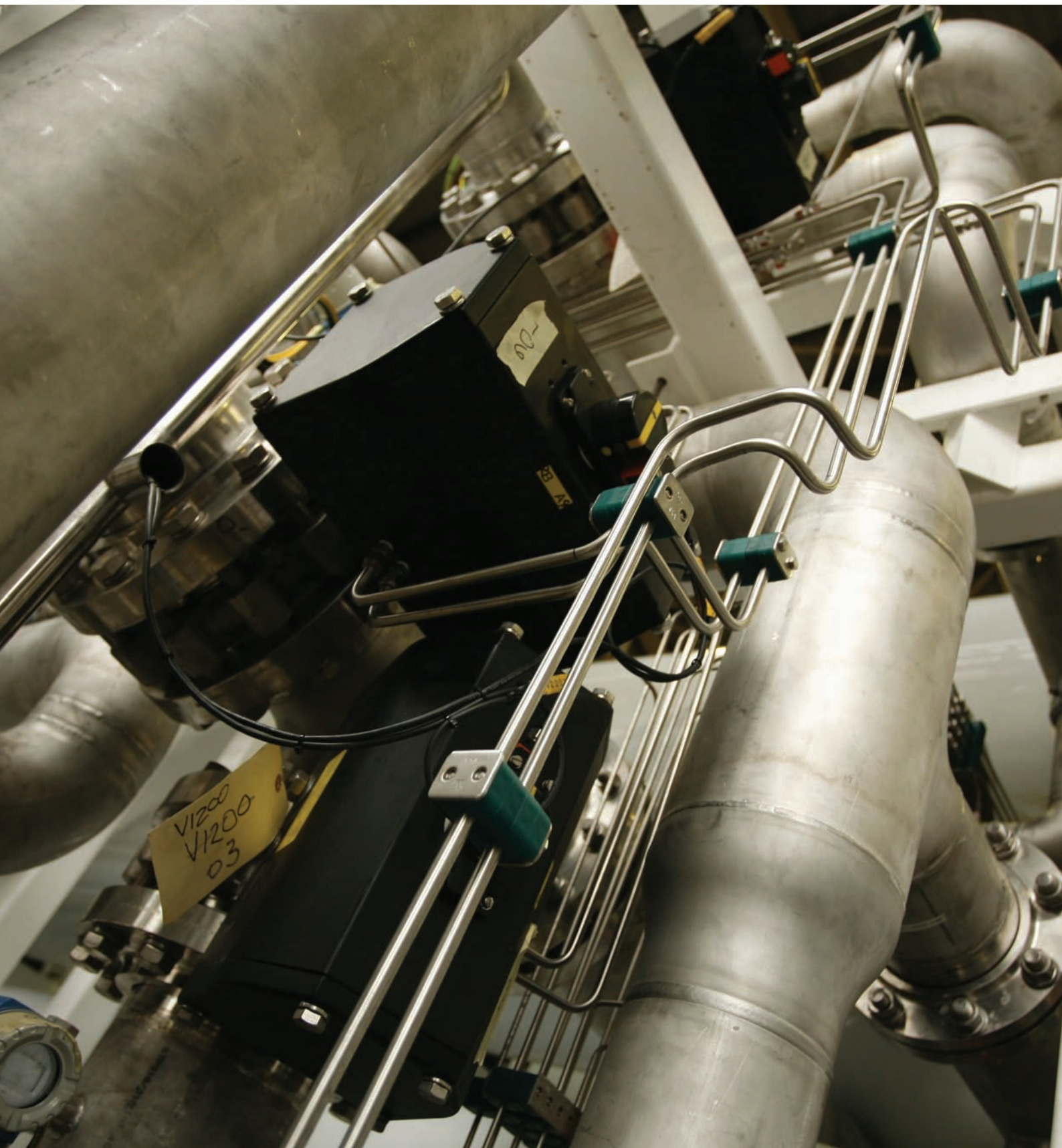

PROUDLY SPONSORED BY



EDITED AND PUBLISHED BY THE AUSTRALIAN STAINLESS STEEL DEVELOPMENT ASSOCIATION
PRINT POST APPROVED PP451207/00205

ASSDA

STAINLESS STYLE AND SUNSCREEN



THIS CLEVER DESIGN PROVIDES BOTH AESTHETIC APPEAL AND PRACTICAL BENEFITS



Form and function have long been the essence of good design, which is why the transformation of this Canberra building is such a success.

ASSDA member and Accredited Fabricator Interspace Manufacturing Pty Ltd was commissioned to design and fabricate screens to update the building aesthetically, as well as provide the workers inside the building with protection from the sun.

Interspace Managing Director Jorgen Hansen said the unique design of the mesh transformed the facade of an ordinary building into an interesting piece of architecture.

“Not only is the design aesthetic, but the

screen helps reflect a percentage of the sun’s rays from entering the office windows,” Mr Hansen said.

“Woven wire mesh is a versatile product and can be used in a number of different applications, such as security, suncreening, cladding, partitions, balustrades, ceiling panels and facades, as seen in our Canberra project.”

The final project, which cost \$95,000, incorporated 321 woven mesh panels in grade 304 stainless steel measuring approximately 540mm x 1900mm each. The mesh was supplied by ASSDA member Metal Mesh from Terrey Hills, NSW.

Mr Hansen said stainless steel was used for

the project because of its longevity in external environments and the minimal maintenance required to keep it looking brand new.

“Stainless steel has a durability that will last the lifetime of the building and, with periodic washing, its appearance will be retained, often with no other maintenance necessary - an important and cost-effective factor.”

CONTACT

> Interspace Manufacturing
 Mr Jorgen Hansen, Managing Director
 35 Allingham Street
 CONDELL PARK NSW 2200
 Phone (02) 9791 9300
 Website www.interspace-aust.com

WHAT’S COOKING?

Bruce Harding is not the first person to be frustrated by rusty cast iron hotplates and grills on his barbecue – the difference is that he did something about it.

Drawing on more than 25 years experience in the stainless steel industry, Mr Harding and his team at Equipment Tech Pty Ltd have developed a range of stainless steel hotplates, grills and baking dishes (sold under the name of Topnotch) that can be retro-fitted to almost any barbecue.

The company uses austenitic T304 and ferritic stainless steels, which are mostly supplied by ASSDA members Sandvik and Atlas Specialty Metals.

Mr Harding said these stainless steel grades played an important role in addressing the design challenges, including the ability to expand and contract under heat.

“The grades we have selected really work together with our design to prevent food sticking to the hotplates and grills,” Mr Harding said.

Laser cutting and a specially developed electropolishing procedure are used to fabricate the products.

Equipment Tech has produced over 100,000 Topnotch stainless steel cooking surfaces since launching the product commercially 5 years ago.

CONTACT

> Equipment Tech Pty Ltd
 Mr Bruce Harding, Managing Director
 79 Percival Road
 SMITHFIELD NSW 2164
 Phone (02) 9729 4652
www.topnotchbbq.com.au



HYGIENE A PRIORITY FOR FOOD PRODUCTION



Hygiene is a top priority at a facility which processes more than 40,000 tonnes of chicken a day, so it is not hard to imagine the scale of stainless steel fabrication needed to meet that expectation.

ASSDA member and Accredited Fabricator Stainless Metal Craft has recently completed work on the design and fabrication of stainless steel equipment for Inghams Enterprises' processing plant at Edinburgh Park, north of Adelaide, and hatchery at Monarto, south of Adelaide.

The projects incorporate numerous custom-designed installations, including a series of 300mm wide channelled drainage at the processing plant in runs of 60m that will withstand the weight of forklifts, and slot drains with integrated sumps (Figure 1) at the hatchery that will tolerate extremely harsh cleaning compounds.

Stainless Metal Craft General Manager Graeme Bunt said the slot drains, in particular, were a specialised project requiring innovative tool work, because of the size and depth required.

He said the slot drains were fabricated at their facility at Emu Plains, NSW, then shipped to Adelaide in 8m lengths where they were site welded to form continuous drains of 44m.

Mr Bunt said grades 304 and 316 were both used at the facilities, depending on the application.

"For most of the general usage areas, such as laundry chutes, bump rails, hand rails, hands-free wash stations, walk-through showers and chequer plate platforms and stairs, we were able to use 304," Mr Bunt said.

"But in more specialised areas or where harsh chemicals may be used, such as slot drains, some clean points, freezer coving, boot washers and fire hose reel cabinets, we had to use 316 to ensure the material would withstand the harsh environment."

Mr Bunt said freezer coving (a hygiene

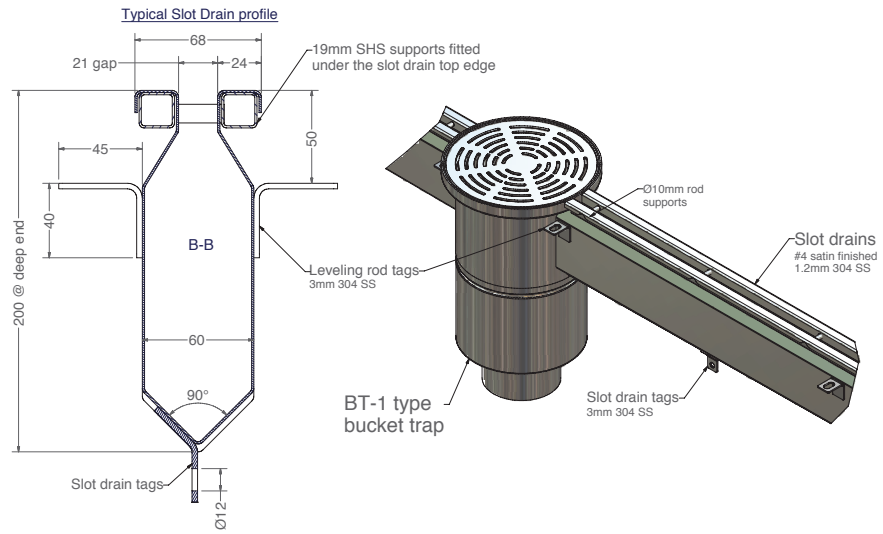

Figure 1: Slot drain profile with integrated sump

requirement to prevent food from being caught where the wall meets the floor) is usually made from epoxy-coated concrete, but there was concern this would wear down with ongoing snap freezing of the chickens. Instead, about 180m of 3mm grade 316 were used.

Strict regulations within the food industry also determined the need for grade 316 stainless steel fire hose reel cabinets.

Mr Bunt said most of the stainless steel was supplied by ASSDA members Atlas Specialty Metals and Midway Metals.

The processing plant was handed over to Inghams at the end of September and the hatchery will also be handed over this year.

CONTACT

> Stainless Metal Craft
Mr Graeme Bunt, General Manager
6 Bromley Street
EMU PLAINS NSW 2750
Phone (02) 4735 5666
Website www.smcstainless.com.au

STAINLESS STEEL STATISTICS

FURTHER PROCESSING PLANT

- 55 hands-free wash stations
- 80 clean points
- 180 metres of freezer coving
- 12 boot washers
- 18 fire hose reel cabinets
- 300mm wide channelled drainage in runs of 60 metres – strong enough to withstand weight of forklifts

HATCHERY

- 495 metres of slot drains
- 10 hands-free wash stations
- 800 metres of Schedule 40 pipe bump rails
- 45 clean points
- 7.7 square metre egg shell hopper

404GP™ & 445M2. The rising stars in a new generation of stainless steels

- 404GP™ has the corrosion resistance of 304 often better
- 445M2 has the corrosion resistance of 316 often better
 - Easy to fabricate • Easier on tools
- Offers significant cost advantages over 304 & 316

Available ex stock in sheet and coil

ADVERTISEMENT

SYDNEY
(02) 9827 0790

MELBOURNE
(03) 9409 8500

BRISBANE
(07) 3722 0800

ADELAIDE
(08) 8345 1033

PERTH
(08) 9258 2600

Alternative stainless steel grades



THIS ARTICLE IS THE SECOND OF A TWO-PART SERIES OUTLINING NEW AND EMERGING STAINLESS STEEL GRADES WHICH MAY BE CONSIDERED AS ALTERNATIVES TO THE MORE TRADITIONAL AND WIDELY KNOWN VARIETIES

The growing demand from China and the rest of the developing world has driven up the price of the alloying elements in stainless steels. The relative cost of different grade groups of stainless steels has also changed, depending on the content of the more expensive alloying elements, particularly nickel and molybdenum.

In the last issue we described the austenitic 200 series group, one of the alternative groups to the austenitic 300 series that traditionally dominate the market. This article describes the other two alternative groups, ferritic and duplex grades.

FERRITIC 400 SERIES

These stainless steels have the ferritic structure also found in carbon steels. They do not contain the nickel addition used to stabilise austenite in 300 series grades. The quality of ferritic grades has advanced with modern steelmaking equipment and, after several generations of ferritic grades, a number of technical limitations have been overcome.

Toughness is the remaining limitation that has not been overcome. All ferritic grades show the ductile to brittle fracture transition well known from carbon steels. Unlike the carbon steels, there is no phase transformation when heated during welding, and hence the grain size of the HAZ can be high. This limits the toughness of the ferritic stainless steels, and with a few exceptions they are used at up to about 3mm thickness, where the toughness transition temperature after welding is adequate.

There are ferritic grades with 10.5-30% chromium, and many also contain molybdenum. The ferritic grades have the corrosion resistance their chromium and molybdenum contents give them, and in addition they are very resistant to stress corrosion cracking. Later generations of ferritics are not susceptible to sensitisation and intergranular corrosion.

The ease of fabrication of ferritic grades, which behave in a similar way to carbon steel, has seen them used to replace competing materials and grow the market for stainless steels. A recent publication of the International Stainless Steel Forum "The Ferritic Solution – The Essential Guide To Ferritic Stainless Steels" (available from ASSDA) has several examples.

Mechanical and Physical Properties

Yield strength is a little higher than that of the austenitic grades, and tensile strength a

Some ferritic and duplex grades in comparison to austenitics 304 and 316

Grade	Cr	Mo	N	Ni	C	Mn	Other	PRE*
AUSTENITIC 300 SERIES								
304	18.1			8.1	0.04			18
316	17.2	2.1		10.2	0.04			24
FERRITIC 400 SERIES								
409	11.5				0.02		0.18Ti	12
430	16.5				0.04			17
AWM 404GP™	21.0				0.010		0.4Cu, 0.3Ti	21
444	17.7	1.8			0.02		0.45(Ti+Nb)	24
AWM 445M2™	22.1	1.05			0.007		0.20Ti, 0.20Nb	26
DUPLEX								
LDX 2101®	21.5	0.3	0.22	1.5	0.03	5.0		29
SAF 2304®	23.0	0.3	0.10	4.8	0.02			27
2205	22.0	3.1	0.17	5.7	0.02		0.15N	37
SAF 2507®	25.0	4.0	0.27	7.0	0.02		0.3N	46

* Pitting Resistance Equivalent (PRE) = %Cr + 3.3x%Mo + 16x%N

little lower. Ductility is about half that of the austenitics, and is similar to carbon steel.

Ferritic grades cannot be strengthened by heat treatment, and since their work hardening is weak they are rarely strengthened by cold work. Ferritic stainless steel work hardens in a similar way to carbon steel, which can be an advantage, particularly in fabrication where experience and settings gained with carbon steel can be applied to ferritic stainless steels with few modifications.

Ferritic grades are ferromagnetic, and have much lower thermal expansion and higher heat conductivity than austenitic grades.

Attributes

First generation ferritic stainless steels are usually used unwelded, as they have high carbon (~0.05%), which causes the formation of brittle films of low corrosion resistance on HAZ grain boundaries. Grade 430 is the most widely used of this group: it has enough corrosion resistance for indoor applications such as food preparation and display equipment, but is rarely fusion welded. Grade 430 is usually used with a bright annealed (BA) finish: finishes in ferritic grades are generally brighter than their austenitic equivalent. Large amounts of first generation ferritic grades, with molybdenum added for extra corrosion resistance, are used for automotive trim.

Second generation ferritic stainless steels have lower levels of carbon and nitrogen, and have titanium and/or niobium added to combine with what's left. This makes the grades more

weldable, and the first second generation ferritic grade developed, 409, is now widely used in automotive muffler systems. The current production of 409 in USA rivals the tonnage of the most popular stainless steel, 304. Welds in second generation grades are tough at room temperature up to about 2mm thickness, and do not suffer from sensitisation or stress corrosion cracking. There are titanium treated versions of 430, widely used in whitegoods such as welded washing machine drums.

Third generation ferritic grades have even lower carbon, nitrogen, titanium and/or niobium additions, with higher contents of the corrosion-resisting elements chromium and molybdenum. The most common grade of the group, 444, is used for challenging applications such as heat exchangers and hot water tanks.

Fourth, or new generation grades, are further refined using vacuum equipment to achieve better toughness and weldability, and better surface quality. They are often used in applications where austenitic grades fail by chloride stress corrosion cracking or pitting corrosion, and they are increasingly being used in many applications to replace the common austenitic grades.

Limitations

The limited toughness of ferritic grades has been noted, and they are rarely used in structural applications.

A further limitation is the tendency of ferritic stainless grades to suffer 475°C embrittlement

and phase formation more quickly than austenitic grades, which limits their use to about 350°C in the higher chromium grades. However, large tonnages of the lower chromium grades are used in automotive muffler systems at higher temperatures without problems.

Applications

The largest tonnage of ferritic grades is used in automotive muffler systems, and there are also significant uses in automotive trim, commercial catering equipment and indoor decorative applications. The higher alloyed later generation grades give outstanding performance in heat exchanger and piping systems for chloride-containing aqueous solutions and seawater, where stress corrosion cracking of austenitic grades can be a problem. The ferritics are also ideally suited for roll forming to roofing, walling and rainwater goods.

DUPLEX GRADES

These grades consist of an intimate mixture of about equal amounts of austenite and ferrite. About half of the amount of nickel needed to be fully austenitic at the chromium content is added in most of the grades. A newer grade, LDX 2101, follows the approach of the 200 series austenitics by using manganese instead of most of the nickel.

There are grades within the duplex group with a range of different corrosion resistances, depending on the chromium and molybdenum contents. The duplex grades tend to use more chromium and less molybdenum than an austenitic grade of similar corrosion resistance - a more economical balance.

As chromium is increased in the austenitic 300 grades to improve corrosion resistance, more nickel must be added, making high chromium austenitic grades expensive. The more corrosion resistant duplex grades, containing less nickel and a better balance of chromium and molybdenum, have penetrated the market to a greater extent than the leaner alloys, and 2205 has become the most common alloy where the corrosion resistance of grade 316 is inadequate.

The duplex grades are much more resistant to stress corrosion cracking than the austenitic grades, and they are effectively immune in potable water. They are also less prone to sensitisation than austenitic grades, although not immune.

Mechanical and Physical Properties

Duplex grades have about twice the tensile strength and 50% higher yield strength than austenitic grades. The ductility is about half, but is still high enough to give good formability, with work hardening behaviour similar to that of carbon steels. Unwelded, duplex grades are tough to low temperatures (-50 to -100°C), and they can often be welded to give transition temperatures well below 0°C.

Duplex grades cannot be strengthened by heat treatment, and since their work hardening is weak they are rarely strengthened by cold work.

Duplex grades are ferromagnetic, and have lower thermal expansion and higher heat conductivity than austenitic grades.

Attributes

Their much higher strength than austenitic grades often allows duplex grades to be down-gauged to thinner material, with good savings in costs.

The higher strength can be a handicap if the opportunity of down-gauging is not taken, as forming loads are high and may be beyond the capability of the equipment. Many of the uses of duplex grades are at thicker gauges (greater than ~1.2 mm), where the savings of down-gauging can be achieved without getting to the lighter sheet metal gauges that fabricators can find difficult to weld.

Welding duplex grades requires more control of welding parameters, particularly heat input and interpass temperature, but pre-heat, post-heat and post-weld heat treatment are not required and weldability is considered good.

Limitations

The high alloy content of most duplex grades makes them susceptible to embrittlement from the formation of intermetallic phases after extended service at high temperatures.



Corrosion resistance is also reduced. Service temperatures are generally limited to less than about 300°C.

Applications

The higher strength of the duplex grades makes them suitable for large tanks, and savings of 40% or more in material costs can be achieved. They are also used for heat exchangers and chemical equipment, often where chloride stress corrosion cracking has limited the life of austenitic grades.

Comparison of typical tensile and elongation properties of grade groups of stainless steels

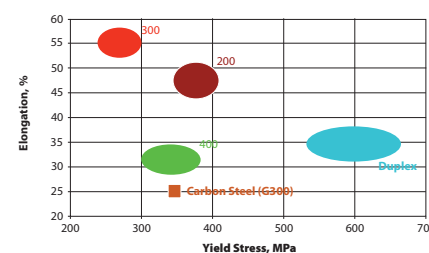
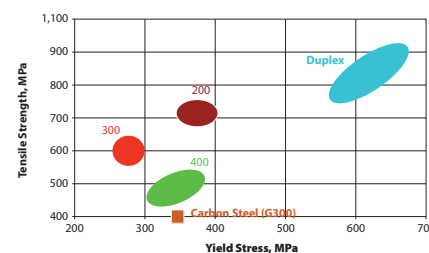

www.elg.com.au



SYDNEY: 70 Cosgrove Road, Enfield NSW 2136 Phone (02) 9642 8900

MELBOURNE: 170 Northbourne Road, Campbellfield Vic 3061 Phone (03) 9305 3535

Recyclers of Stainless Steel and other Associated Alloys

ELG > Largest processor of stainless steel scrap in both Australia and the World.

ELG > Specialises in selling reusable, downgrade and redundant stock to the overseas market.

ELG > Committed to offering excellent prices and service.

ADVERTISEMENT

STAINLESS ADVANCE FOR WATER TREATMENT PLANT



Never has there been a time in Australia when water preservation was so critical. As populations rise and dam levels fall, the importance of treating and reusing water has become not a question of "if" but a question of "when".

The construction of Bundamba Advanced Water Treatment Plant (BAWTP) west of Brisbane is aimed at alleviating pressure on South East Queensland's existing dams and waterways by providing an alternate water supply for end users in the region, initially Swanbank power station.

The project has had great flow on benefits for the Australian stainless steel industry as infrastructure requirements point to the material for its strength, corrosion resistance and application performance.

The world-class BAWTP is a joint venture between Thiess Pty Ltd and Black & Veatch, who are responsible for the engineering, design, procurement and construction. Management of the project is in alliance with the Queensland Government. A number of ASSDA members were sub-contracted by Thiess Pty Ltd for various stages of the project, including ASSDA Accredited Fabricator D&R Stainless, Perfab Engineering and Stainless Pipe and Fittings Australia.

Following a tender process, D&R Stainless was engaged for off-site pipe spooling. The quantity of stainless steel used for the job, including around 3000 flanges, meant that D&R Stainless was issued with the materials by Thiess Pty Ltd as needed.

Many of the piping materials for the first two stages of the project were supplied to Thiess



External pipes at the Bundamba Advanced Water Treatment Plant

Pty Ltd by Stainless Pipe and Fittings. Materials were in excess of 350 tonnes and included pipe, pipe fittings and flanges in grade 316L with sizes ranging from 25-600nb.

Once delivered, D&R Stainless cut and bevelled the pipe and then welded and passivated internally and externally before undergoing hydro testing.

D&R Stainless Director Karl Manders said that, not only did the pipes use grade 316, but they were also fabricated to Australian Standard 4041, class 1.

"Because the pipework adhered to such a high standard, 10% of all welds were x-rayed for quality," he says.

Passivation of the pipe welds involved applying pickling paste inside and out, and then scrubbing and flushing to avoid loose scale, important for the fine filtration of the water treatment plant.

Karl says quality was something Thiess Pty Ltd took very seriously, with a welding inspector and quality checker appointed at their premises.

"This was to ensure all welding and passivation was performed at the highest standard, and also to ensure that production off-site was consistent with installation schedules onsite".

Perfab Engineering was also sub-contracted by Thiess Pty Ltd for the manufacture of the reverse

ADVERTISEMENT

AUSTFLUID LINK

ASIA PACIFIC PTY LTD ABN: 99 119 516 568

FOR ALL YOUR *STAINLESS STEEL* REQUIREMENTS

BSP
JIC

NPT
Metric Threads



Tube Fittings, Flanges
Hose Tails, Adaptors
Ferrules
Quick Release Couplings
Metric & Imperial Tube



Rothwell Qld 4022
Ph: 61 - 7 - 32042540
Mob: 0419 758 198



Email: stainless@primus.com.au
Web: www.austfluidfittings.com.au
Fax: 61 - 7 - 32040022

ASSDA STAINLESS STEEL

TECHNICAL HOTLINE

Contact ASSDA on 07 3220 0722 or visit www.assda.asn.au

FREE TECHNICAL SUPPORT AND SUPPLY ADVICE

STAINLESS ADVANCE FOR WATER TREATMENT PLANT

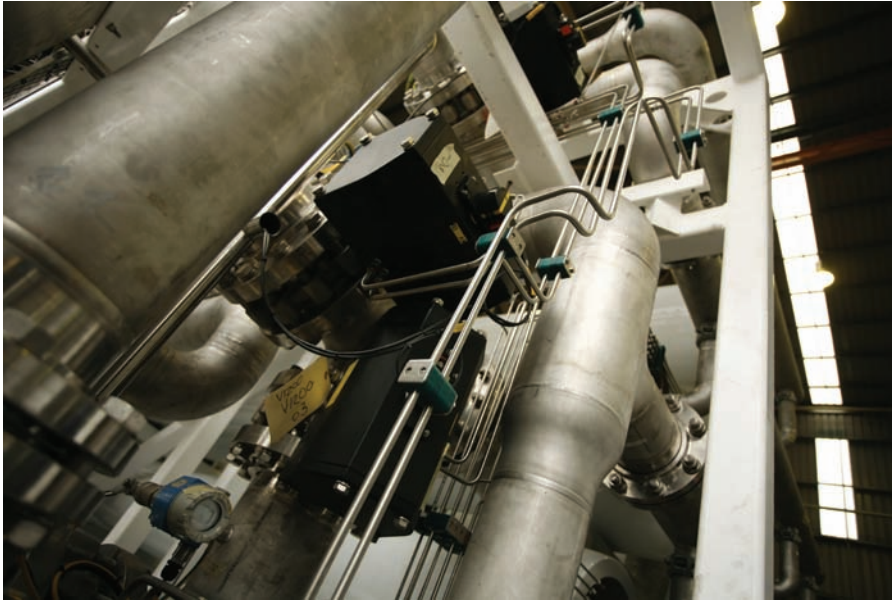

Perfab Engineering manufactured the reverse osmosis skids

osmosis (RO) skids at its workshops in Newcastle, working closely with the designers from suppliers Koch Membrane Systems in the United States.

The work carried out by Perfab included fabrication and surface treatment of the carbon steel skid frames, fabrication of the stainless steel pipework, full mechanical installation of the valves, instrumentation and RO pressure vessels, pneumatic fitout, electric fitout and testing.

The high pressure pipe spools were fabricated from Sch 40S pipe with 300# flanges and low pressure pipe spools from Sch 10S pipe with 150# flanges.

Perfab has three orbital Gas Tungsten Arc Welding (or TIG) machines that were operated around the clock to ensure the tight delivery times were achieved, however Perfab Engineering General Manager Damien Ryba says "the biggest contributor to the success of the job was having a well trained, highly skilled and productive workforce committed to the success of the project".

At present, the BAWTP 1A is in full operation and delivering water to the Swanbank Power Station. Thiess Black and Veatch Director, Gus Atmeh, said that the BAWTP 1A project was delivered ahead of schedule and this was due to the support of the project by high quality stainless steel fabrication shops from across Australia and particularly from South East Queensland, who provided stainless steel components for state of the art process equipment and piping: "Without them we could not have made it on time."



CONTACT

- > D & R Stainless
Mr Karl Sanders, Director
87 Antimony Street
CAROLE PARK QLD 4300
Phone (07) 3879 3599
Fax (07) 3879 3898
www.drss.com.au

- > Stainless Pipe and Fittings
Mr Graham Yarker, Managing Director
17-21 Coulson Way
CANNING VALE WA 6155
Phone (08) 9456 1800
Fax (08) 9456 1700
www.spfa.com.au

- > Perfab Pty Limited
Mr Damien Ryba, General Manager
18 Martin Drive
TOMAGO NSW 2322
Phone (02) 4964 0500
Fax (02) 4964 8410
www.perfab.com.au

Prochem Stainless Steel Specialists



Partnering Industry for 50 years



www.prochem.com.au



After months of hard work from ASSDA and its industry partners, an e-learning module which teaches the basic underpinning knowledge and skill requirements of Gas Tungsten Arc Welding (TIG) is nearing completion.

The purpose of the e-learning module is to rapidly develop welding skills appropriate for the stainless steel industry to assist in overcoming the skills shortages.

ASSDA received seed funding from the Australian Flexible Learning Framework to produce an e-learning module which teaches the underpinning knowledge and basic principles of Gas Tungsten Arc Welding.

The national training system's e-learning strategy, the Australian Flexible Learning Framework, promotes the use of technology

in the delivery of education and training to strengthen the skills base of Australia.

The module takes full advantage of the resources e-learning has to offer, by utilising video, audio, text, images and interactives.

The module is self-paced but takes around one hour to complete. It is also linked to competencies, equipping students with the underpinning knowledge they require in order to begin their practical learning.

If you would like to demo the module, or would like to be involved in the satisfaction report, please email Debbie Govier at debbie_g@assda.asn.au.



Australian Flexible Learning Framework
supporting e-learning opportunities

VALE GARY JOHN DRUMMOND: MR 5CR12

4 JULY 1952 - 14 JULY 2007

Gary was born into the stainless steel industry. His father Doug was one of the early users of stainless steel in the commercial refrigeration industry. Growing up with Doug, Gary learnt a lot about stainless steel and those who knew Gary well thought this would be his future, but it was not to be. Gary was to make his own way in the stainless steel distribution industry that he came to love with a passion. As with other legends in the stainless steel business, Gary had a love affair with stainless steel: it lasted for over 35 years.

Gary's career in the distribution of stainless steel started as a 20 year old when he joined Atlas Steels as a trainee. His first job was as an inside salesman and he progressed from there. From the beginning of his journey in stainless steel, Gary was different – he was always looking for a different and better way

of doing things to create that competitive advantage, which meant a better margin and great customer relationships. Gary carried this philosophy with him throughout his career.

Gary left Atlas after about 10 years of dedicated service. He had reached the point of needing to move into management, where he could use his initiative, drive, and enthusiasm to build something for himself.

I was always proud to have been Gary's early mentor at Atlas. After some short stays at other stainless steel distributors, Gary arrived at Sandvik and met another mentor, Peter Edwards. Gary had found his home and his destiny. Gary built Sandvik to what it is today through his ability to recognise the need for value adding through in-house processing equipment, new products such as 5CR12, and his ability to choose very good people who

were trained to be the best in their fields. Gary was a leader in achieving the highest margins in the industry and he was proud of this ongoing success. Gary always remained committed to the belief that to sell on price was to die on price. He reached his pinnacle at Sandvik and his management expertise was responsible for Sandvik's ongoing success.

People like Gary Drummond don't come along every day in the stainless steel industry. He is missed by his many friends and mates – we are all the poorer with his passing. I have lost a great friend and mate.

Gary is survived by his wife Carol and his three children: Carson, Alexander and Elly.

Prepared by Bob Preston, who was NSW State Manager of Atlas Steels when Gary started with the company.

ASSDA MAJOR SPONSORS



ASSDA SPONSORS

Acerinox Australasia Pty Ltd
Arcelor Stainless International
BHP Billiton Stainless Steel Materials
Nisshin Steel Co. Ltd
OneSteel Sheet & Coil
Outokumpu Stainless
ThyssenKrupp Stainless International GmbH
Valbruna Australia Pty Ltd
Stoddart (Tom Stoddart Pty Ltd)

EDITORIAL AND ADVERTISING

EDITORIAL — Contributions of story ideas specialising in stainless steel and its applications are welcome from members and non-members of ASSDA.

ADVERTISING — Advertise in the only publication that targets more than 8 000 readers in the stainless steel industry. Advertising rates available on request.

CONTACT — Debbie Govier debbie_g@assda.asn.au

MORE INFORMATION

Enquiries for further information on any material presented in this publication should be directed to:

Australian Stainless Steel Development Association
Level 15, 215 Adelaide Street
Brisbane Queensland 4000 Australia
Phone: 07 3220 0722
Fax: 07 3220 0733
Email: assda@assda.asn.au

DISCLAIMER

ASSDA sources articles and advertisements from a variety of contributors and accordingly does not accept responsibility for the accuracy of the contents of this publication nor the suitability of specific applications referred to herein for any particular use. Competent advice should be sought before acting on any matter contained in this publication.